

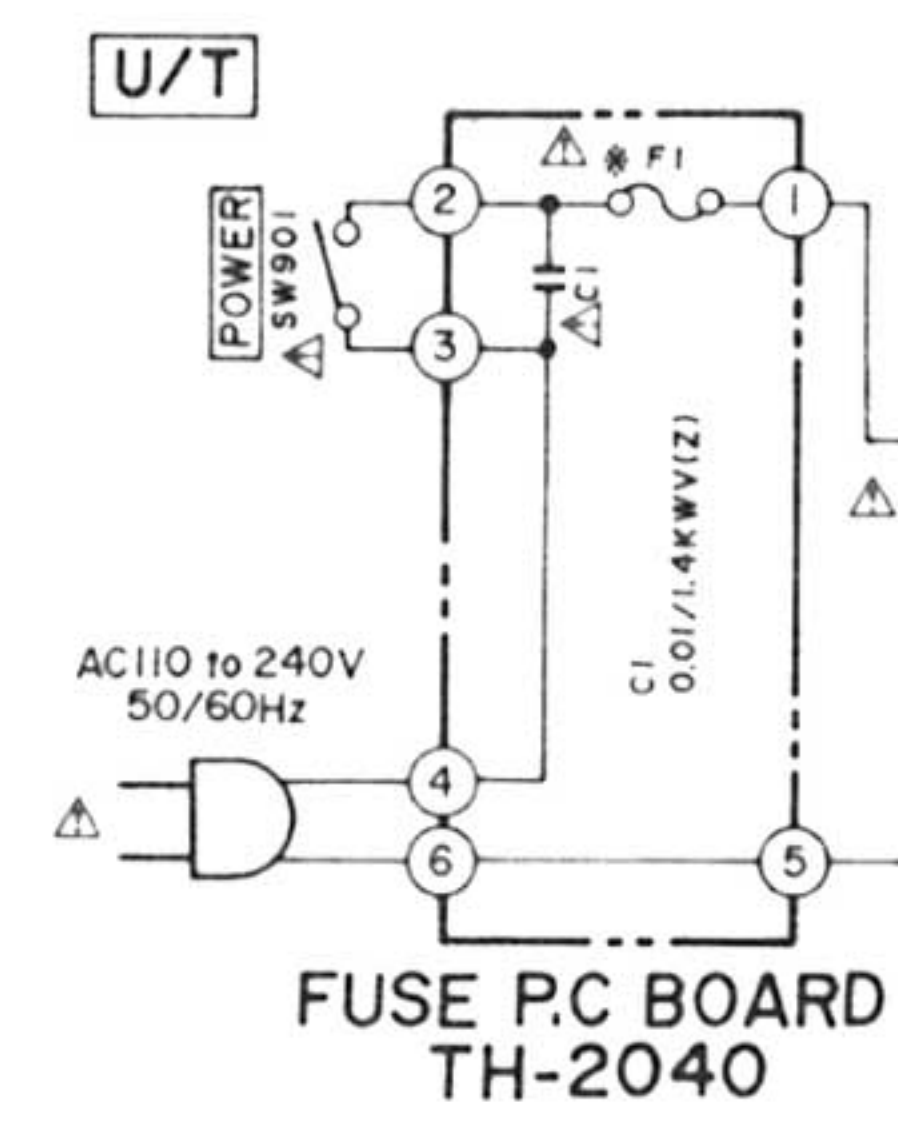

For more Hi-Fi manuals and set-up information
please visit www.hifiengine.com

WARNING: INDICATES SAFETY CRITICAL COMPONENTS FOR CONTINUED SAFETY. REPLACE SAFETY CRITICAL COMPONENTS ONLY WITH MANUFACTURER'S RECOMMENDED PARTS.
AVERTISSEMENT: IL INDIQUE LES COMPOSANTS CRITIQUES DE SÛRETÉ. POUR MAINTENIR LE DEGRÉ DE SÛRETÉ DE L'APPAREIL, NE REMPLACER LES COMPOSANTS DONT LE FONCTIONNEMENT EST CRITIQUE POUR LA SÛRETÉ QUE PAR DES PIÈCES RECOMMANDÉES PAR LE FABRICANT.

	F1	F2	F3	F4	F5
U/T(200V AREA)	250V 1A	250V 1.6A	250V 0.8A	250V 0.8A	250V 0.8A
U/T(100V AREA)	250V 2A	250V 1.6A	250V 0.8A	250V 0.8A	250V 0.8A
JPN, CSA, AAL	250V 2A	250V 1.6A	250V 0.8A	250V 0.8A	250V 0.8A
CEE, UK	T500mA	T1A	T500mA	T1A	T500mA

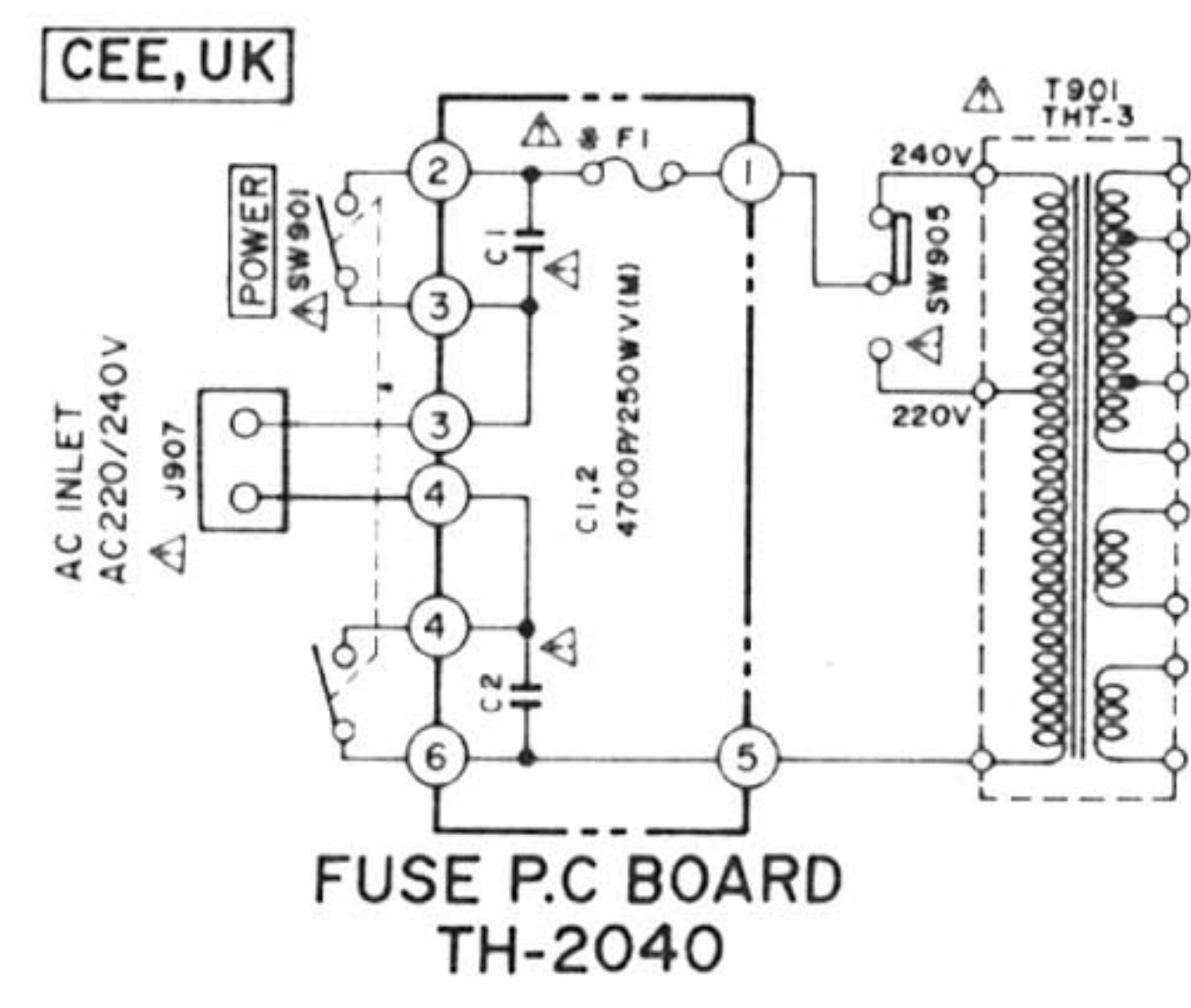
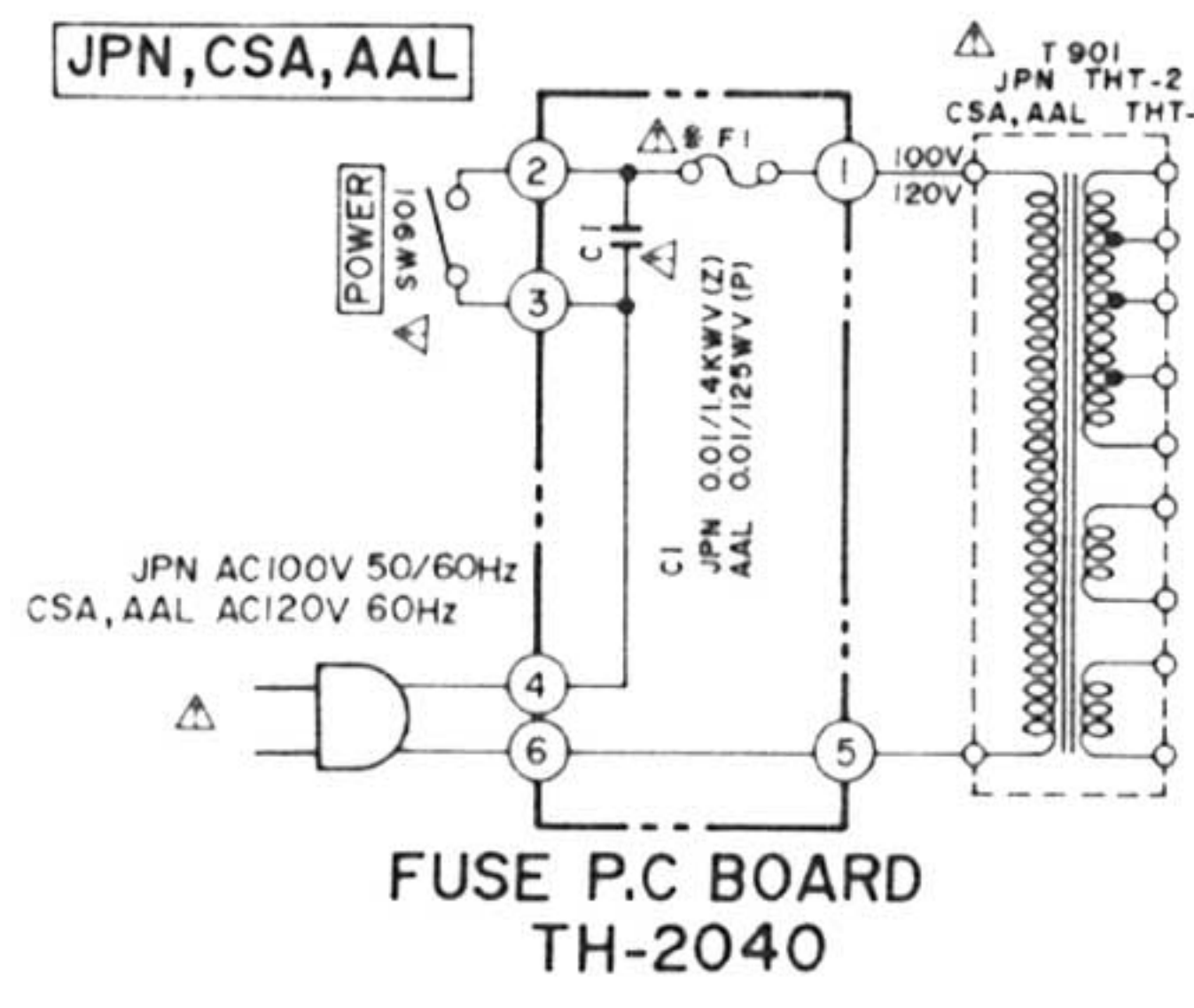

FUSE P.C BOARD TH-2040

PRE AMP P.C BOARD

CAPSTAN MOTOR

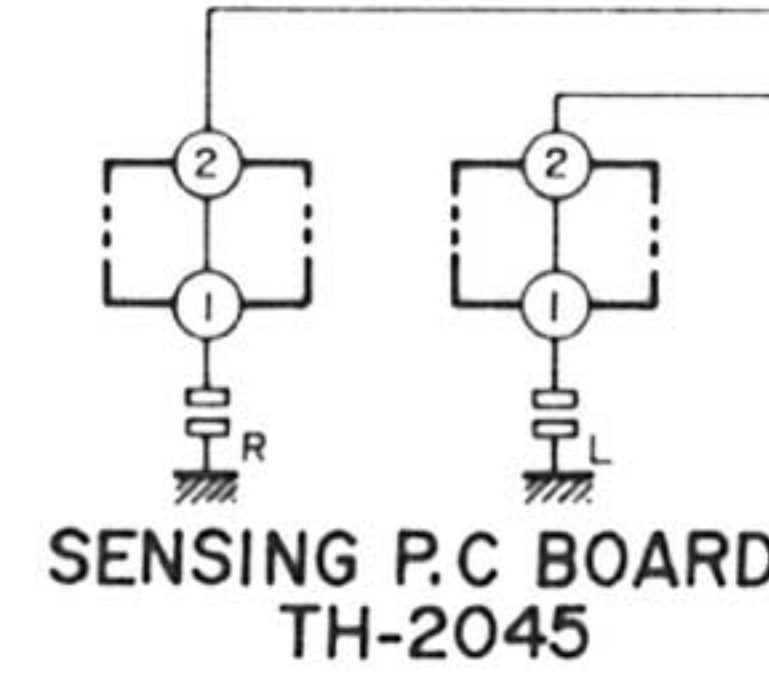
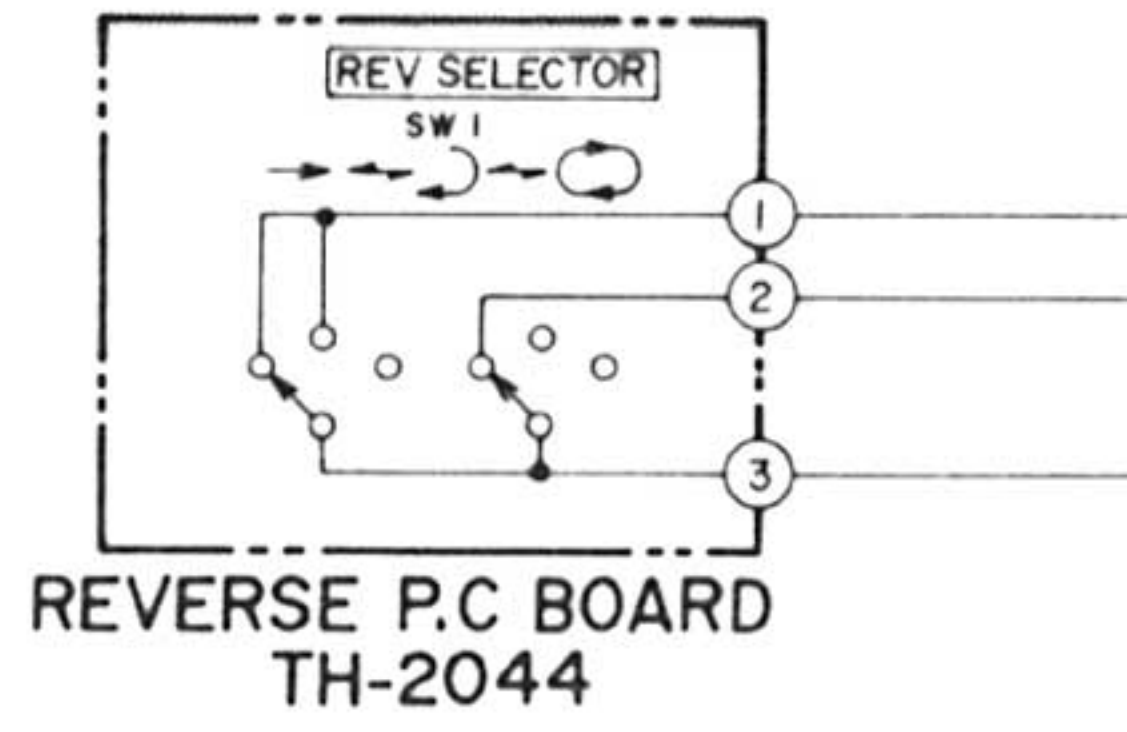

OPERATION P.C BOARD (B) TH-2042

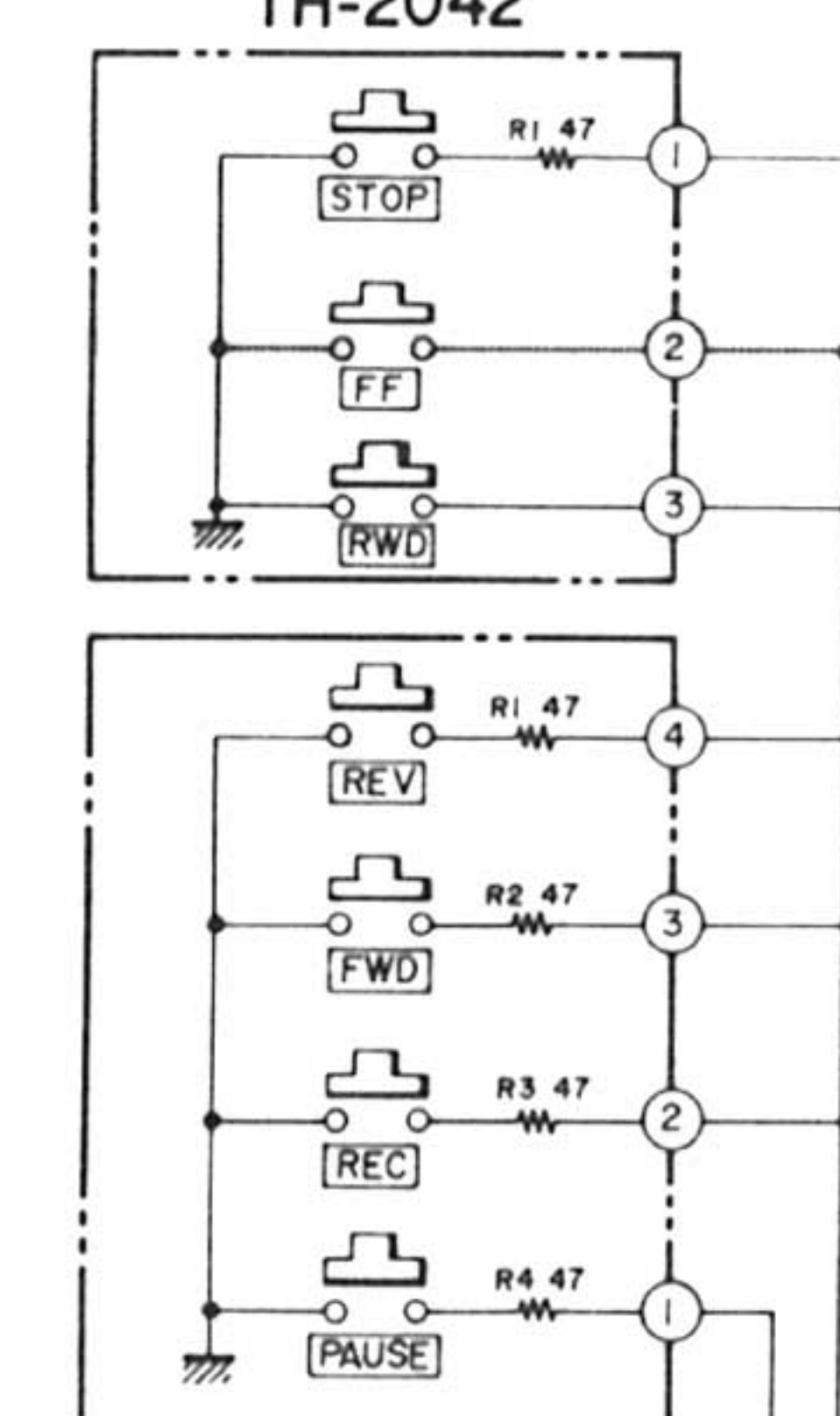

OPERATION P.C BOARD (A) TH-2041

REMOTE CONTROL J905

REC MUTE SW904

DIRECTION P.C BOARD TH-2043

REC MUTE P.C BOARD TH-2046

SYSTEM CONTROL P.C BOARD TH-1015

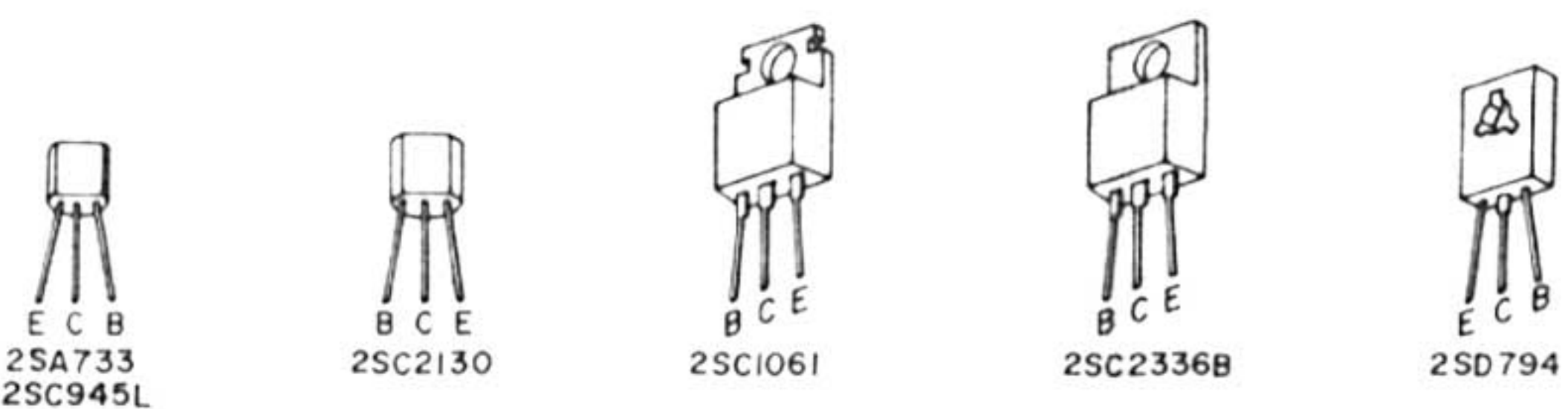

NOTE: UNLESS OTHERWISE SPECIFIED, ALL RESISTORS IN OHMS 1/4W (J). ALL CAPACITORS IN µF 50V (J). POWER TRANSFORMER IS DIFFERENT ACCORDING TO AREA. (—) MARK INDICATES NON POLAR CAPACITORS.



* REC MODE

		7-1/2in	3-3/4in
TR13	B	0.3V	0.3V
	C	22.0V	22.0V
TR14	B	0V	0V
	C	17.0V	14.3V
TR15	B	17.0V	14.3V
	E	16.5V	13.8V
TR16	E	15.9V	13.2V
L1 to 3		-0.4V	-0.2V
4 to 6		15.9V	13.2V
8		65.2V AC	54.0V AC
9		120.4V AC	101.8V AC
TR17,18	E	0V	0V

PRE AMP P.C BOARD TH-5001A

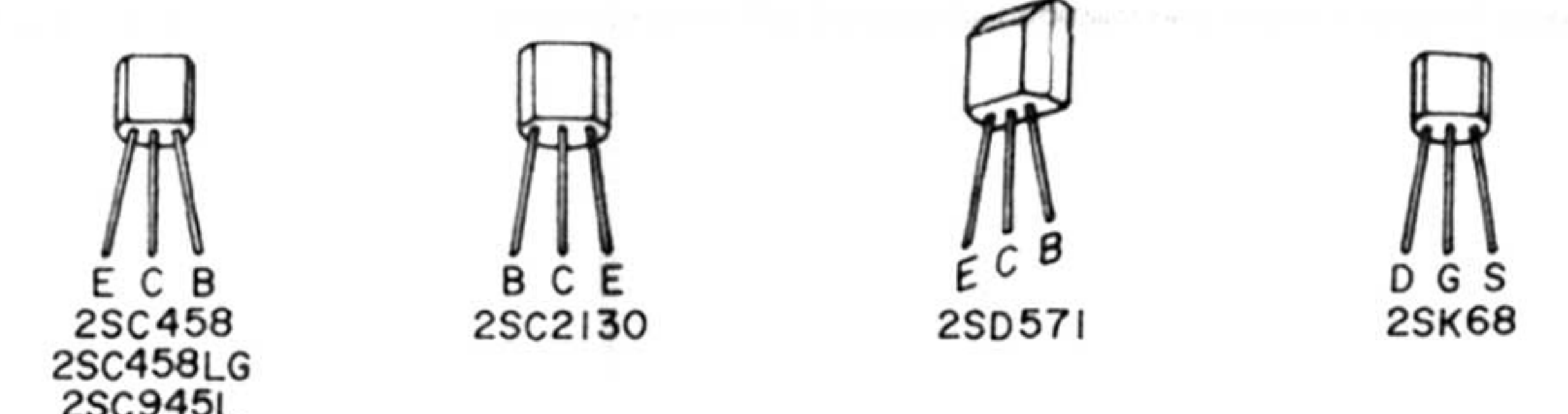

NOTE
UNLESS OTHERWISE SPECIFIED
ALL RESISTORS IN OHMS 1/4W(J)
ALL CAPACITORS IN μF 50WV(K)
(LL)=LOW LEAKAGE CAPACITOR

GX-635D AMP
SCHEMATIC DIAGRAM
NO.2-2 1562417A

2) PRE AMP P.C BOARD TH-5001A (2ED) & REC LED P.C BOARD TH-5001B

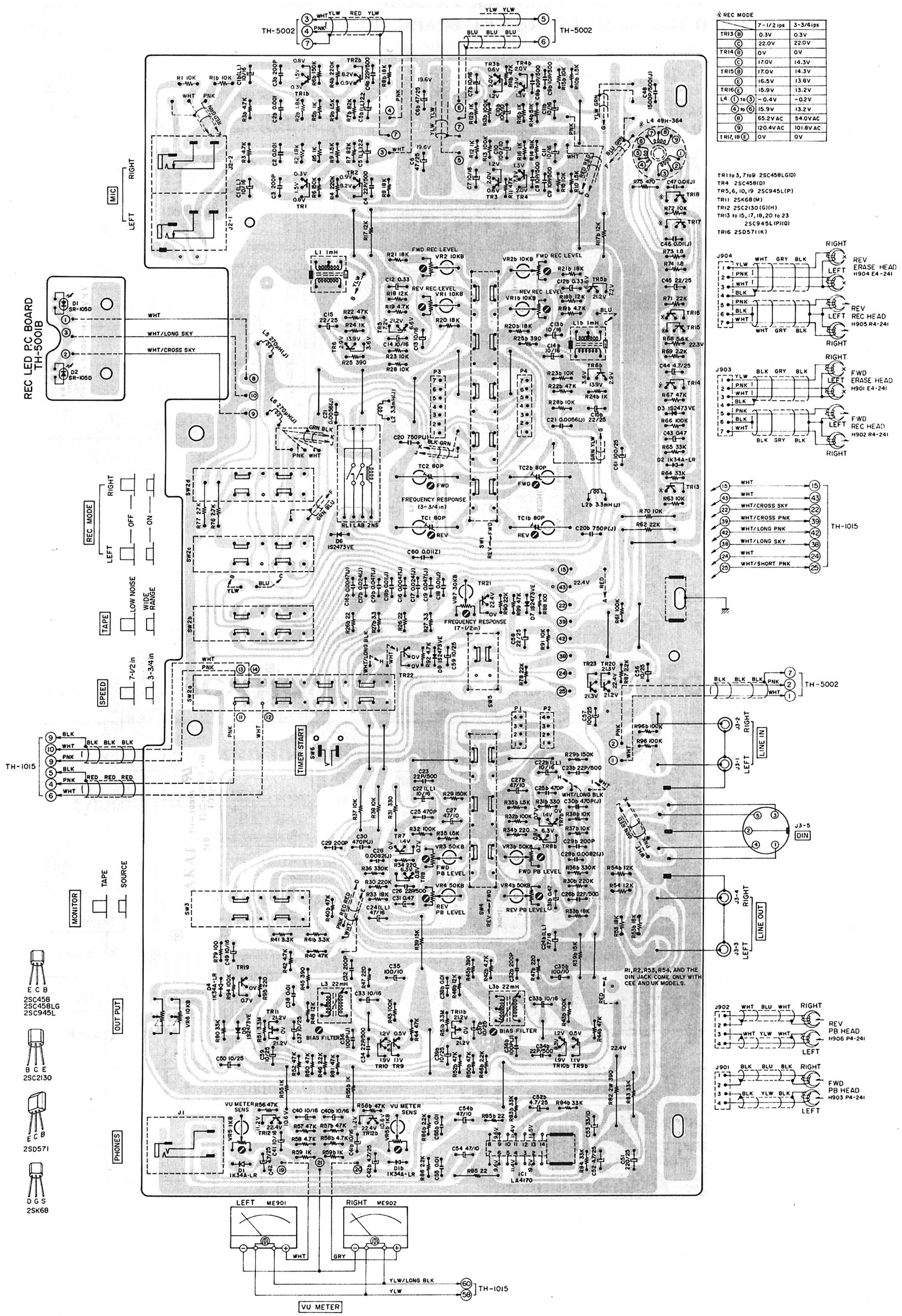

REC MODE

	7-1/2 ips	3-3/4 ips
TR13 (B)	0.3V	0.3V
TR14 (C)	22.0V	22.0V
TR15 (D)	17.0V	14.3V
TR16 (E)	17.0V	14.3V
TR16 (F)	16.5V	13.8V
TR16 (G)	15.9V	13.2V
L4 (1 to 3)	-0.4V	-0.2V
(4 to 6)	15.9V	13.2V
(8)	65.2V AC	54.0V AC
(9)	120.4V AC	101.8V AC
TR17, 18 (E)	0V	0V

TR11 to 3, 7, 10, 9 25C458L(GD)
 TR4 25C458(D)
 TR5, 6, 10, 19 25C945L(P)
 TR11 25K68(M)
 TR12 25C2130(G)(H)
 TR13 to 15, 17, 18, 20 to 23
 25C945L(P)(H)
 TR16 25D571(IK)

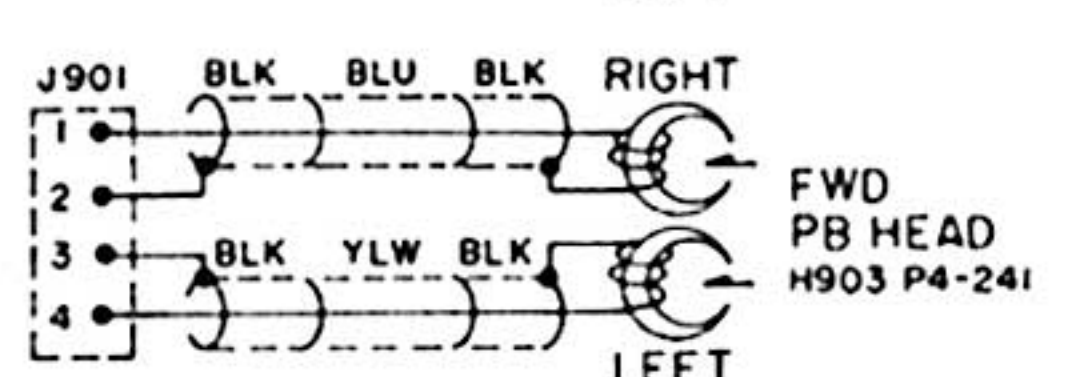
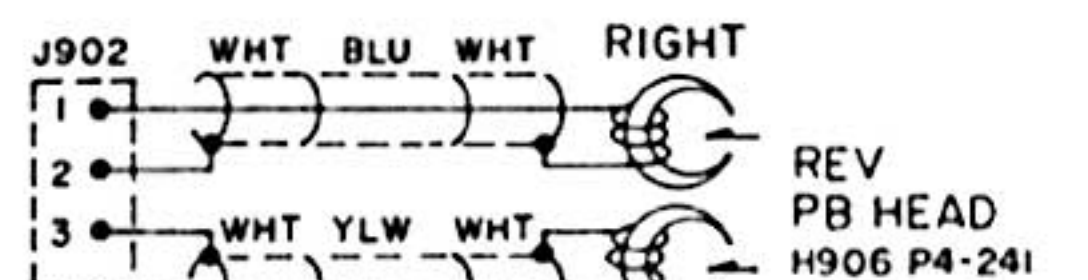
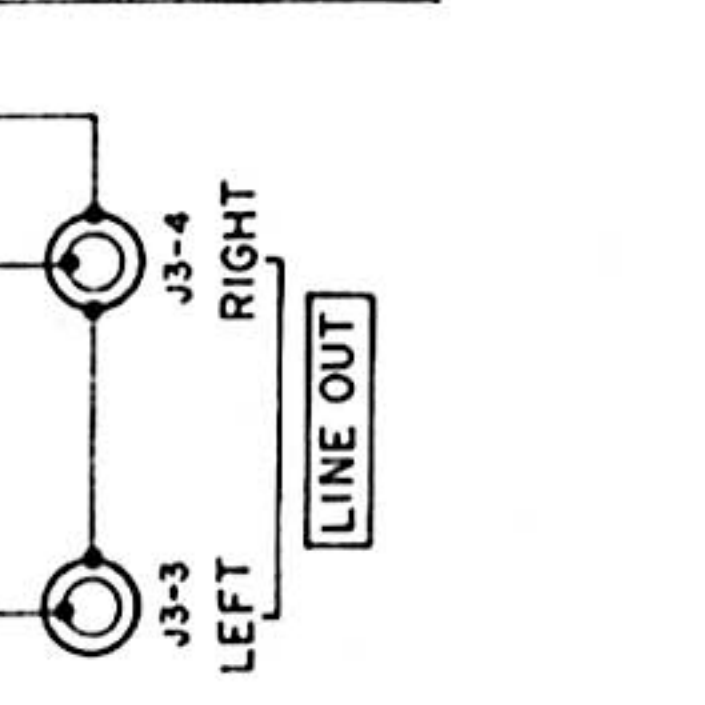
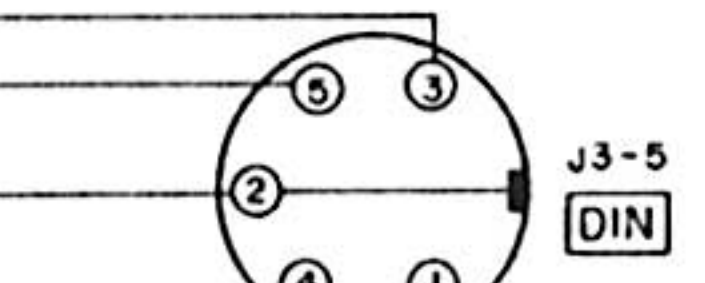
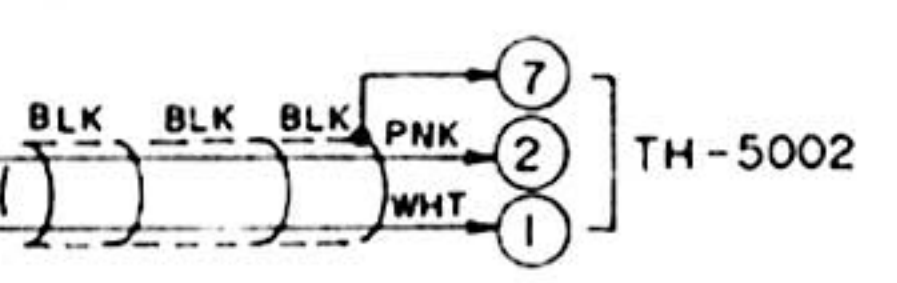
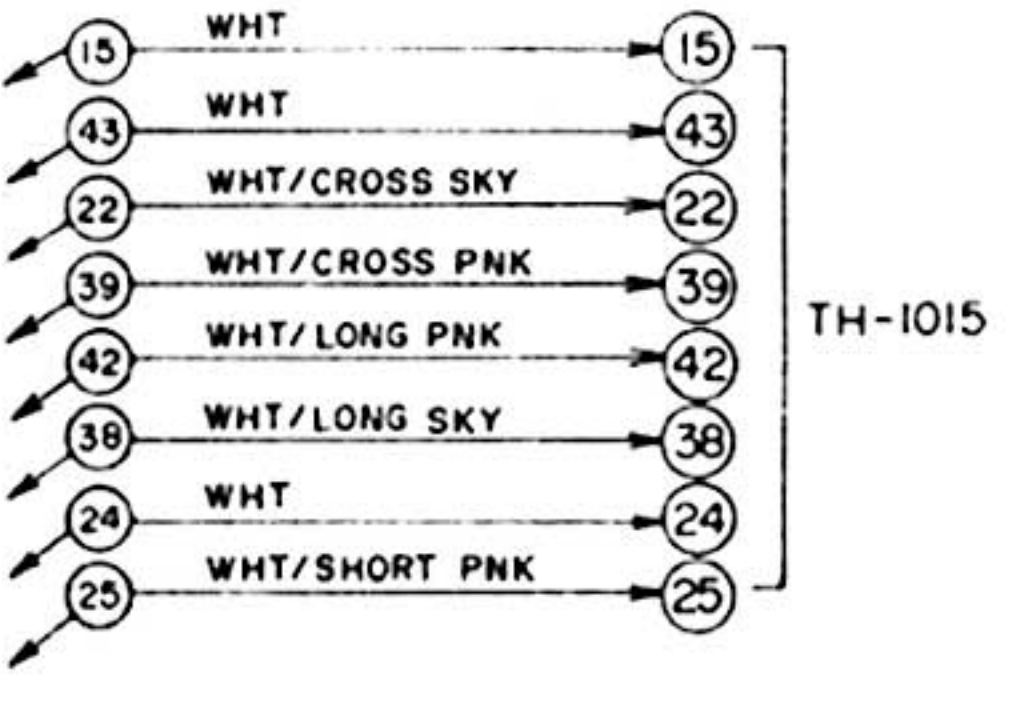
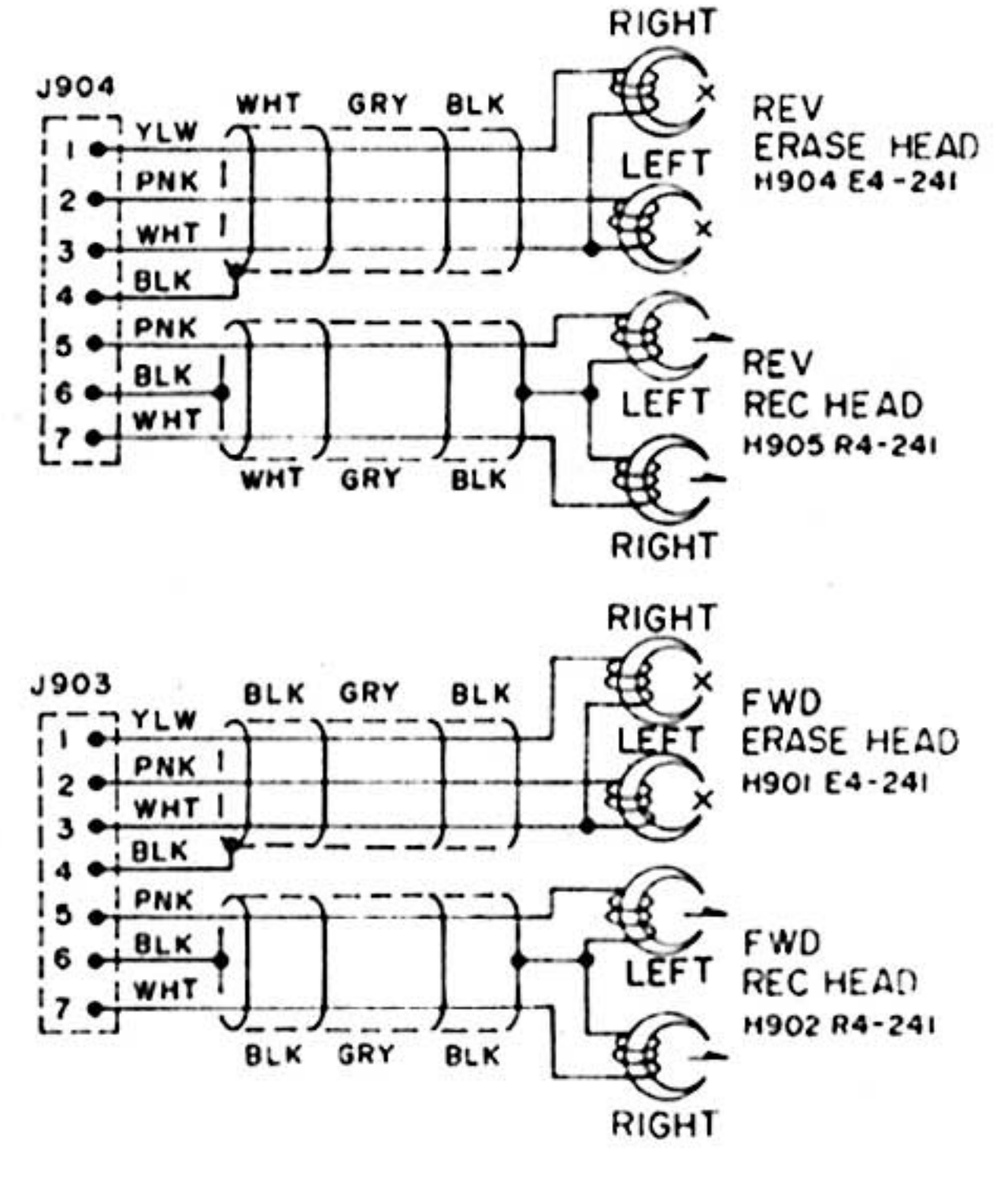

R1, R2, R53, R54, AND THE DIN JACK COME ONLY WITH CEE AND UK MODELS.

- E C B
25C458
25C458LG
25C945L
- B C E
25C2130
- E C B
25D571
- D G S
25K68

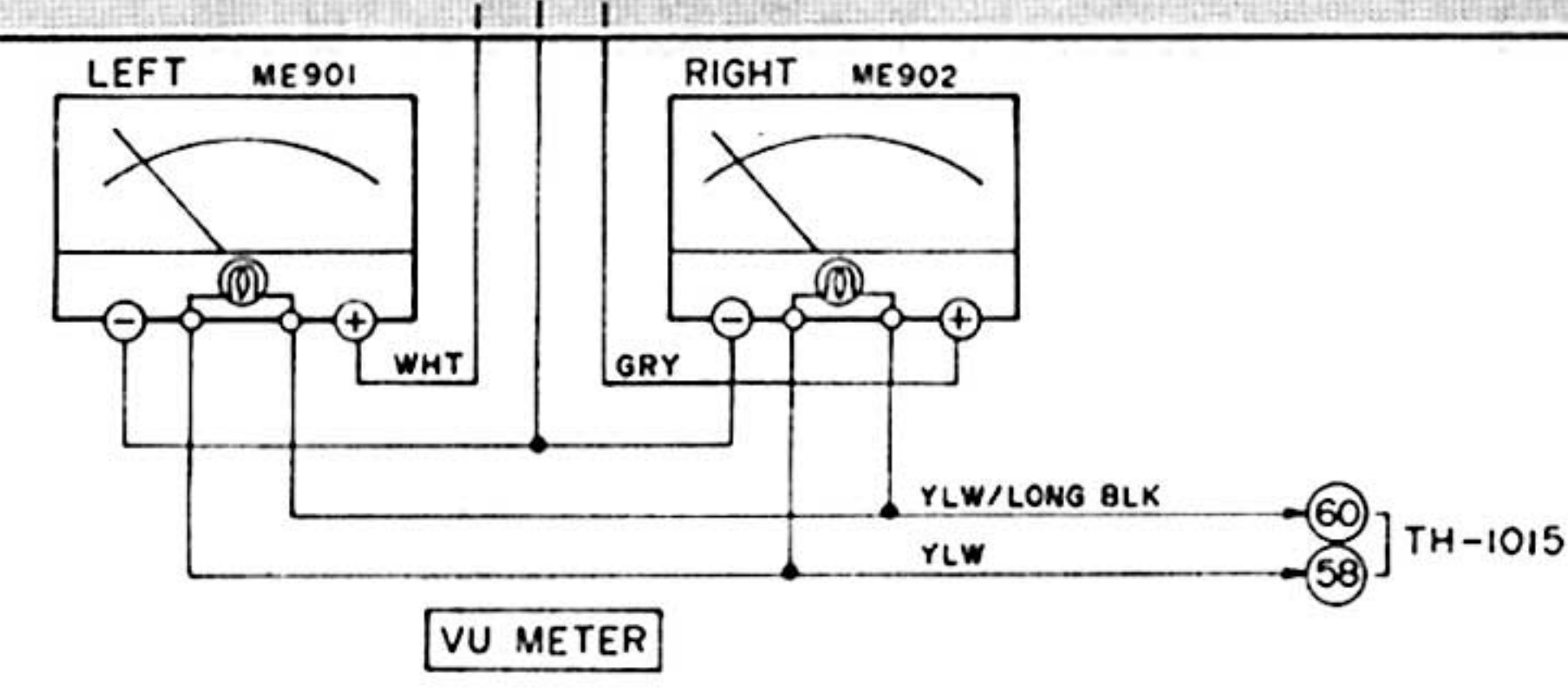

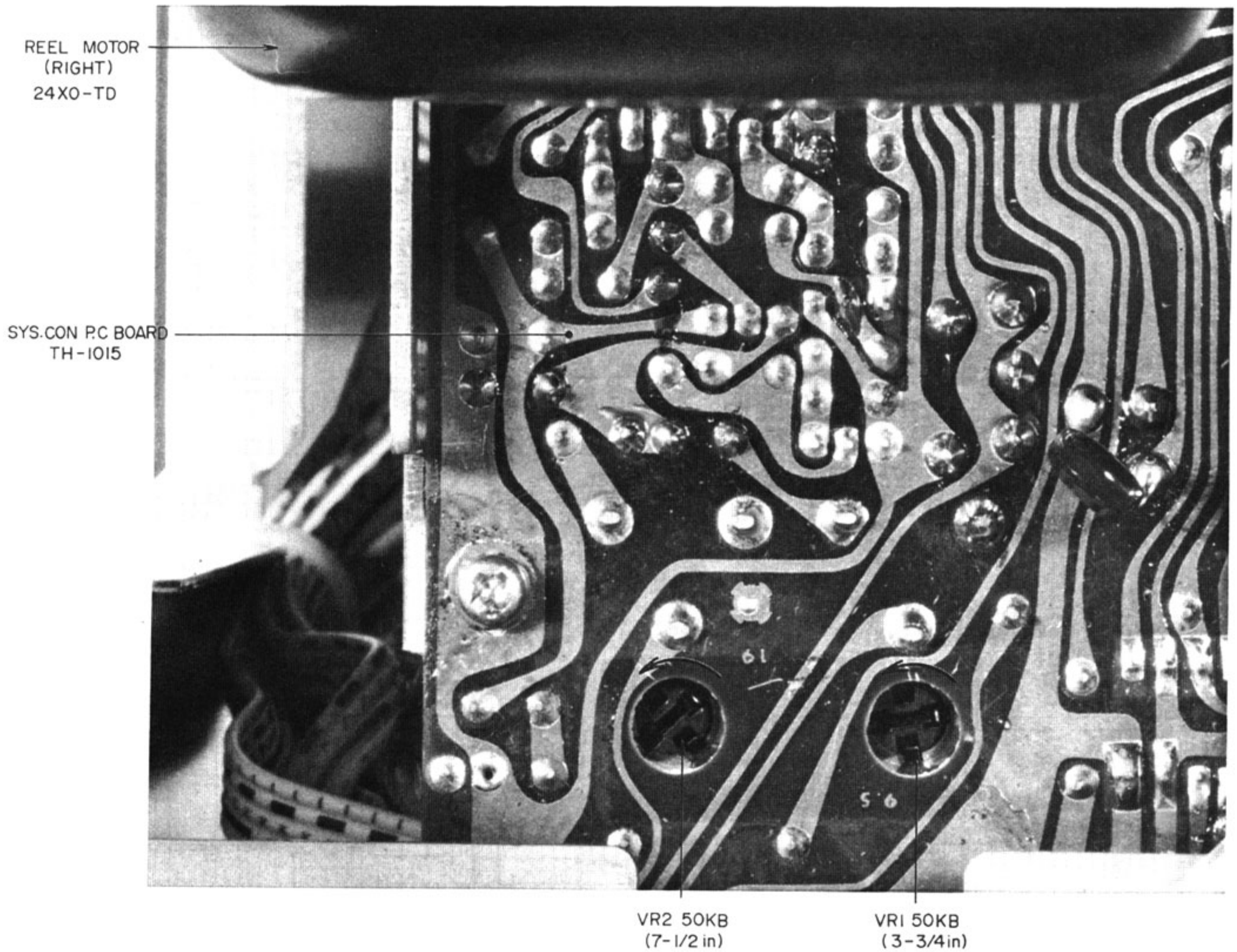

Fig. 16

10. TAPE SPEED ADJUSTMENT

(Refer to Fig. 16)

Set the Tape Speed Switch to 7-1/2 ips and playback the 1,000 Hz, 7-1/2 Test tape.

Connect a frequency counter to LINE OUT and adjust VR2 50 kB until the counter reads 1,000 Hz $\pm 0.5\%$.

Next, set the Tape Speed Switch to 3-3/4 ips and adjust VR1 50 kB until the frequency counter reads 500 Hz $\pm 0.5\%$.

VIII. AMPLIFIER ADJUSTMENT

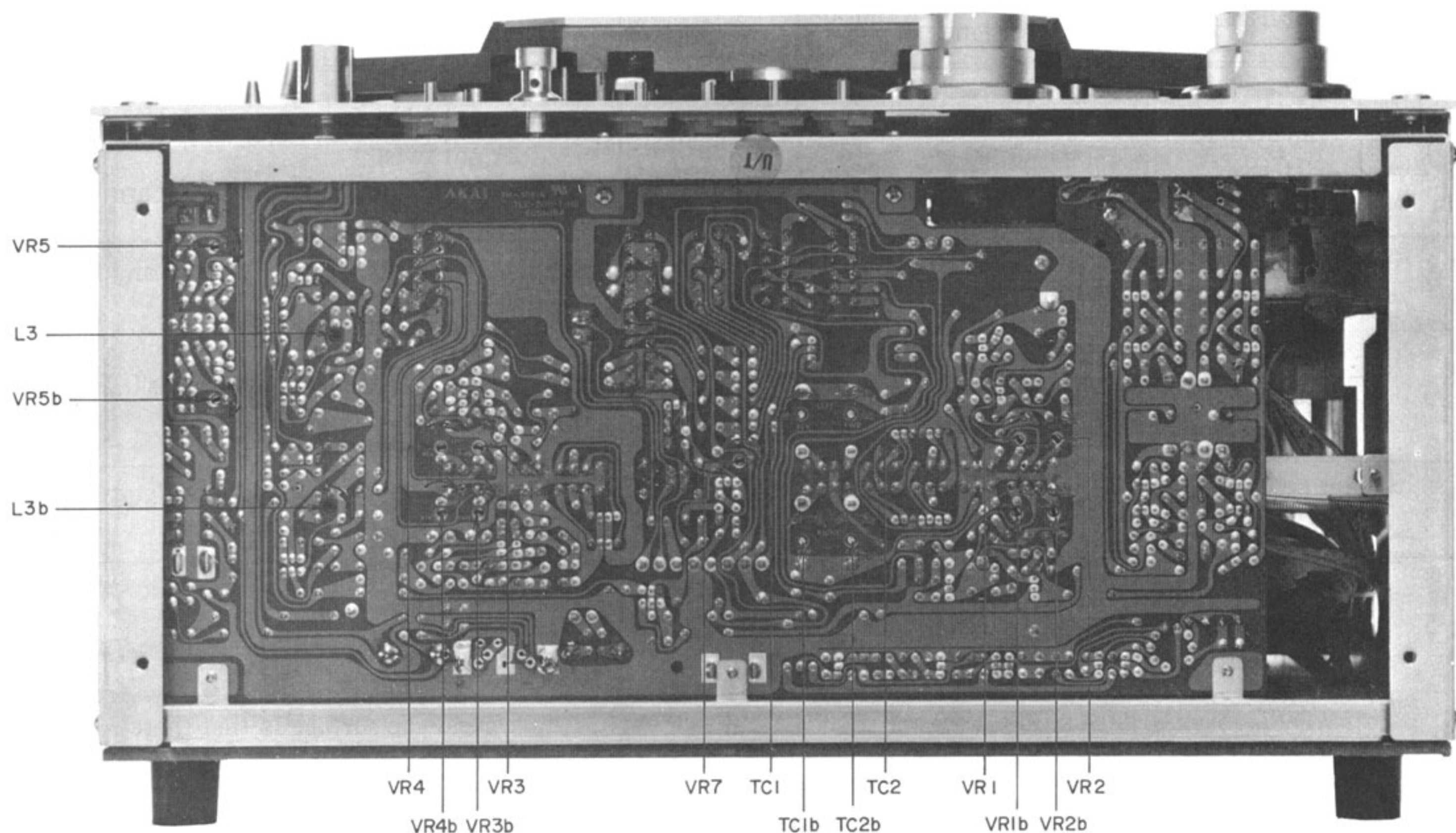

Fig. 18

VR3	50 kB	FWD Playback Level Adjustment
VR4	50 kB	REV Playback Level Adjustment
VR5	1 kB	VU Meter Sensitivity Adjustment
VR2	10 kB	FWD Recording Level Adjustment
VR1	10 kB	REV Recording Level Adjustment
TC2	80 PF	FWD Frequency Response Adjustment (3-3/4 in)
TC1	80 PF	REV Frequency Response Adjustment (3-3/4 in)
VR7	30 kB	Frequency Response Adjustment (7-1/2 in)
L3		Bias Filter Adjustment

* The letter "b" following an adjustment part number indicates "RIGHT CHANNEL".

Step	Adjustment Item	Test Tape Supply Signal	Mode	Adjustment Point	Result	Remarks
1	FWD Playback Level	700Hz 7-1/2 ips 0VU Test Tape	FWD	VR3 50 kB	0±0.5dBm (0.775V)	
2	REV Playback Level	700Hz 7-1/2 ips 0VU Test Tape	REV	VR4 50 kB	0±0.5dBm (0.775V)	
3	VU Meter Sensitivity	700Hz 7-1/2 ips 0VU Test Tape	FWD	VR5 1 kB	0 VU indication	
4	FWD Recording Level	Scotch #211 Tape 1,000 Hz 0 dBm Recording	FWD-REC	VR2 10 kB	0±0.5dBm (0.775V)	
5	REV Recording Level	Scotch #211 Tape 1,000 Hz 0 dBm Recording	REV-REC	VR1 10 kB	0±0.5dBm (0.775V)	
6	FWD Frequency Response (3-3/4 ips)	Scotch #211 Tape 1.5kHz, 15kHz -20dBm Recording	FWD-REC	TC2	1.5 kHz, 15 kHz flat	Tape Speed 3-3/4 ips. Recheck Recording Level.
7	REV Frequency Response (3-3/4 ips)	Scotch #211 Tape 1.5kHz, 15kHz -20dBm Recording	REV-REC	TC1	1.5 kHz, 15 kHz flat	Tape Speed 3-3/4 ips. Recheck Recording Level.
8	Frequency Response (7-1/2 ips)	Scotch #211 Tape 1.5kHz, 15kHz -20dBm Recording	FWD-REC	VR7 30 kB	1.5 kHz, 15 kHz flat	Tape Speed 7-1/2 ips. Recheck Recording Level.
9	FWD Distortion Confirmation	Scotch #211 Tape 1,000Hz 0 dBm Recording	FWD-REC		Less than 0.5%	See NOTE 4
10	REV Distortion Confirmation	Scotch #211 Tape 1,000 Hz, 0 dBm Recording	REV-REC		Less than 0.5%	See NOTE 4
11	Bias Filter		REC	L3	Less than -30 dB	Mic, Line Volume at Max. See NOTE 5.

Chart-5

- NOTES:**
1. Output Level Control should be at maximum.
 2. Except for Steps 6 and 7, set Tape Speed to 7-1/2 ips.
 3. Set Tape Selector Switch to Low Noise position.
 4. If it does not comply with the specifications, repeat Steps 6 and 7, and re-adjust.
 5. Unless the core is moved intentionally this adjustment is not necessary.